

# BRITANNIA

## Premier Stored Pressure Extinguisher BC2 – Carbon dioxide

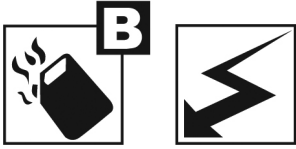

Carbon Dioxide extinguishers are used particularly where cleanliness is required. They are also very effective for electrical hazards such as computers and other types of office equipment.

Carbon Dioxide is also used on class B (flammable liquid) fires.

### key points

- Approved and certified to BS EN3
- Kitemarked product
- CE marked in accordance with the PED
- Colour coded headcap
- Manufactured in Great Britain
- Reliability
- Designed for long service in harsh conditions



### Technical Specification

Model	Capacity (kg)	Fire rating	Full Weight (Kgs)	Temp Range	Operating pressure (Bar) @ 20°C	Discharge Duration (Secs)	Discharge Range (M)	Diameter (mm)	Height (mm)
BC2	2	34B	6.5	-20°C to +60°C	50	10	3	102	580

Britannia Fire reserve the right to alter the specification of the product without prior notice



[www.Britannia-Fire.co.uk](http://www.Britannia-Fire.co.uk)

# BRITANNIA 2KG CARBON DIOXIDE EXTINGUISHER

## ADDITIONAL SPECIFICATIONS

Operating Pressure @ 20°C	50bar
Test Pressure (PT)	250bar
Maximum Allowable Pressure (PS)	169.3bar
Cylinder material	Chromium molybdenum alloy steel
Operating Valve material	Brass
Horn material	Polyethylene
Finish	Polyester Powder Paint

## COMPONENT PARTS

ITEM	DESCRIPTION	PART No.
A	Swivel Horn and Elbow	BC010
B	Brass Tapered Valve	VLV0010
C	2kg Steel CO2 Cylinder	CYL0020
D	Syphon Tube	TUBE0185
-	Pull Tight Seal (not shown)	BRH0175
-	Wall Bracket (not shown)	BRH0540

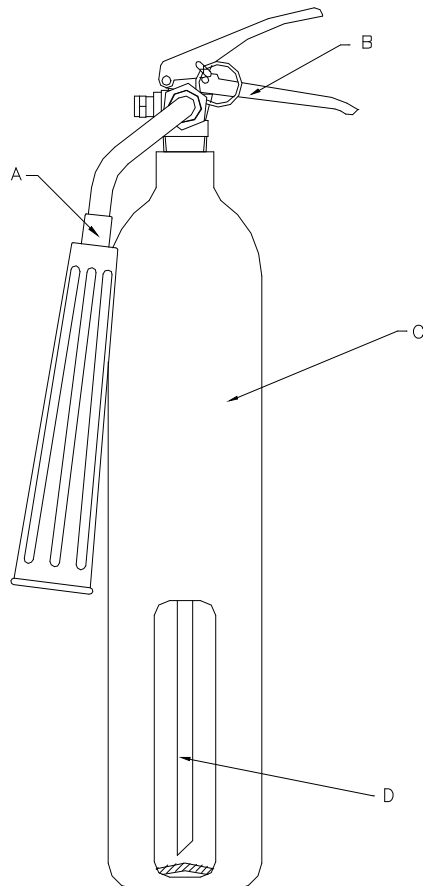

LICENCE NO. KM 6832



0086



**Britannia Fire Ltd**

Ashwellthorpe Industrial Estate, Ashwellthorpe, Norwich, NR16 1ER, ENGLAND

Tel: +44 (0) 1508 488416 Fax: +44 (0) 1508 481753

[www.britannia-fire.co.uk](http://www.britannia-fire.co.uk)